

Morphine Facts & Myths

You are not alone – we are here for you!

Morphine facts:

- The goal is comfort.
- It can still be administered even if a person cannot swallow.
- Used for severe shortness of breath, pain, or restlessness.
- Starts working in 15-30 minutes and lasts roughly 2-4 hours.
- Addiction is not a concern while on hospice care.
- Morphine improves comfort and help manage symptoms.

WHAT TO DO IN THE MOMENT:

If your loved one seems uncomfortable, short of breath, or restless:

- Stay calm, speak gently
- Call Interim Hospice @ **419.879.9394**
- Give Morphine exactly as instructed
- Allow time for it to work
- Keep your loved one positioned comfortably (head elevated, if breathing is difficult)

Morphine myths:

- People who take Morphine will become addicted.
- People who take Morphine will become so sedated that they can't function.
- People who take Morphine die sooner because Morphine causes them to stop breathing.
- Morphine is only for severe pain.

“Morphine helps them feel comfortable and breathe easier. It does not make anything happen sooner... it just prevents suffering.”

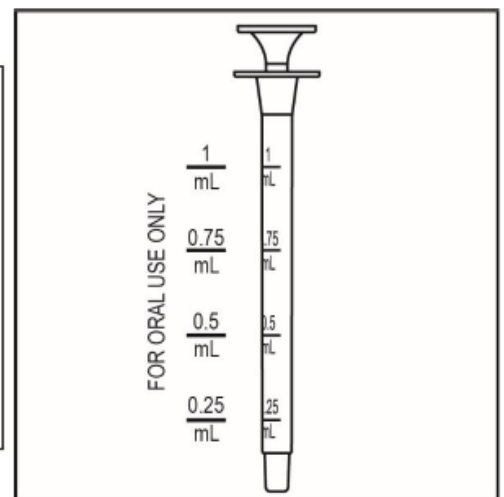
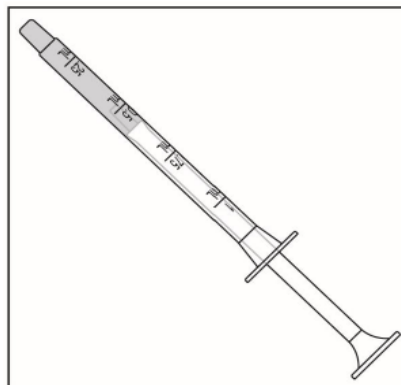
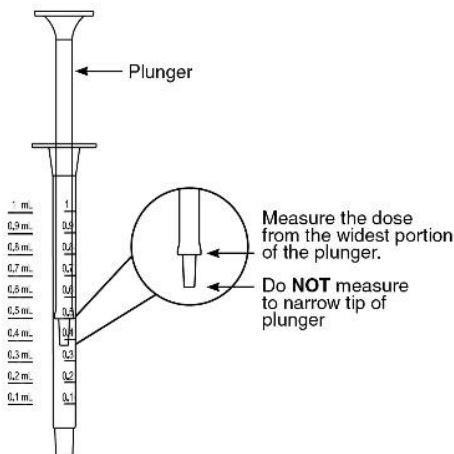

Morphine Facts & Myths

1. People who take Morphine will become addicted.

If used as prescribed and administered correctly, addiction is not a concern in end-of-life care. Our hospice team will monitor dosing to ensure that it is given to alleviate the current symptoms appropriately.

2. People who take Morphine will become so sedated that they can't function.

At lower doses, many people remain alert and active. It comes down to finding the right dose, which is different for each patient's tolerance and goals.

3. Morphine speeds up death.

When used medically, there is not evidence that Morphine shorts the dying process. It is carefully dosed to relieve symptoms and can improve quality of life by making them more comfortable to do activities of daily living.

4. Morphine is only for severe pain.

It is also used to relieve symptoms such as trouble breathing, anxiety, and overall discomfort. Its effectiveness at managing multiple symptoms makes it a valuable tool at improving patient comfort.